

# Tri-Spark - Triple Flex

## Trident & R3 Installation Instructions

### TRI-0003

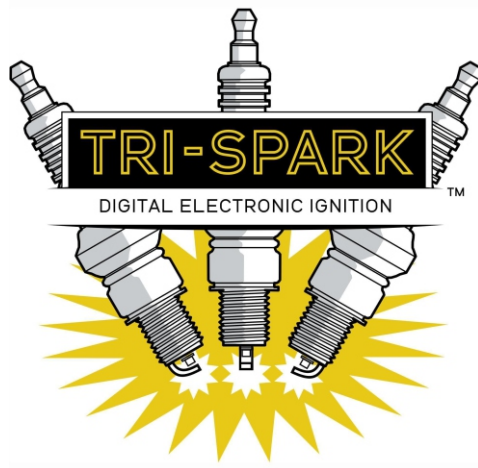

Copyright Tri-Spark 2022

Revised Nov. 2022

## Introduction

Thank you for purchasing the Tri-Spark Triple Flex Ignition system. For your own safety and success with the installation we strongly recommend that you engage a qualified technician to install your new ignition system. The following information is provided to assist them in the installation and setup.

Manual Contents	Page
Preparation	2
Remove the points plate and advancer	3
Install trigger rotor and stator unit	4
Wiring Diagram Positive Earth	5
Wiring Diagram Negative Earth	6
Wiring Mini Coils Positive Earth	7
Wiring Min Coils Negative Earth	8
Static Timing	9
Strobe Timing	9
Specifications	10
Troubleshooting	11
Warranty policy	12

### Step 1: Preparation

Read all the instructions before you begin. Disconnect the battery, remove fuse, seat, side covers and points cover in preparation.

**Caution:** A general inspection and tidy up of all the wiring including inside the headlight shell is highly recommended. Inspection and testing of the charging system prior to installing the system is also **highly recommended**.

**Caution: Use ONLY the recommended ignition coils and coil wiring configurations. Other coils may damage the ignition unit. Do not assume that other options will work or not damage the ignition unit. The 12 volt or 6 volt Lucas style canister ignition coils may be used and must be installed with the supplied diodes. Do not connect these coils without the diodes.**

The digital mini coils may also be used. These must be wired in series without the diodes. Refer to the wiring diagrams for more detail.

The use of resistor spark plug caps OR resistor type spark plugs is recommended.

## Step 2 - Remove the original points base plate and auto advance unit

Remove the points base plate and auto advance unit (AAU). If you have other electronic ignition parts (pickup and trigger rotor) remove those instead.

Disconnect the points plate wiring from the connectors located along the frame. This is made easier if the air filter and side cover are first removed to gain access to the area.

With the pillar bolts removed, the points plate hangs from the wiring. Pull the wires through and remove the whole unit from the engine including the wires.

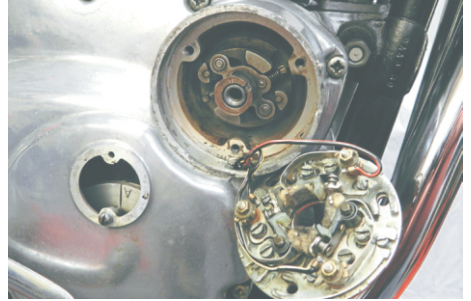

Remove the fixing bolt in the centre of the AAU. A threaded rod or bolt then goes into the AAU to assist removal. The AAU fits into a taper in the exhaust cam and may be difficult to remove.



A few gentle taps with a hammer should get things moving. The AAU comes out as a complete unit.

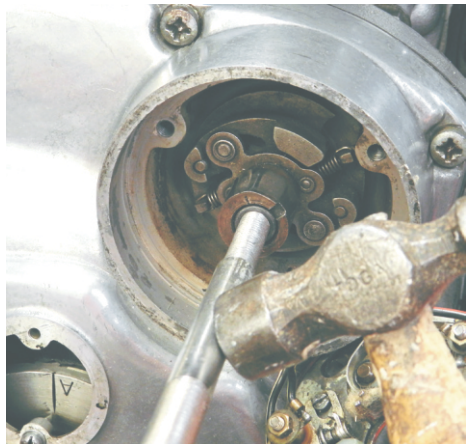

### Step 3 - Install the Trigger Rotor

Select high gear so that the rear wheel can be used to rotate the crankshaft. Rotate the crankshaft forward to top dead centre (TDC) on the number 1 Timing Side cylinder on COMPRESSION STROKE. Both valves should be closed on the compression stroke. The Timing side is your right side as you sit on the bike.

With the timing plunger (Triumph tool #60-1858) screwed into the access hole in the front of the engine, apply light finger pressure on the plunger while slowly rotating the engine BACKWARDS until the plunger engages into the crankshaft.

The "A" or the "B" timing line should now line up with the pointer in the strobe timing port as shown here.



If the plunger tool is not available simply rotate the crank backwards from TDC until the FIRST timing mark lines up with the pointer. In most cases this will be the "B" mark. The crank should now be lined up at 38 degrees BTDC ready for the installation.

Install the trigger rotor as shown above with 22mm centre to centre from one of the magnets to the bolt hole. The socket head screw provided is the correct 1/4 UNF thread. If it bottoms you will need to shorten it - don't force it !

Check that the face of the rotor is 2mm (+/- 0.6) below the deck that the pickup unit sits on. Use the plastic strip provided as a guide. See diagram on page 8.

### Step 4 - Install the Tri-Spark Stator Unit

Install the stator unit as shown here so that the bolts are in the middle of the adjustment slots and the magnet is visible in the hole. Feed the cable through the wire hole carefully. Adjust the cable so that the amount of slack inside the engine looks like the photo.

Run the cable along the bottom frame rail and up the frame beside the oil tank. Pay attention to keep the cable well away from the exhaust pipes and moving parts.

### Step 5 - Connect the wiring

Refer to the wiring diagrams on the following pages. Connect the wiring as shown in the diagram that suits your machine (positive or negative earth). The cable may be cut to length but leave some slack.



# Tri-Spark Triple Flex TRI-0003 Three coil installation - Positive Earth (Ground)

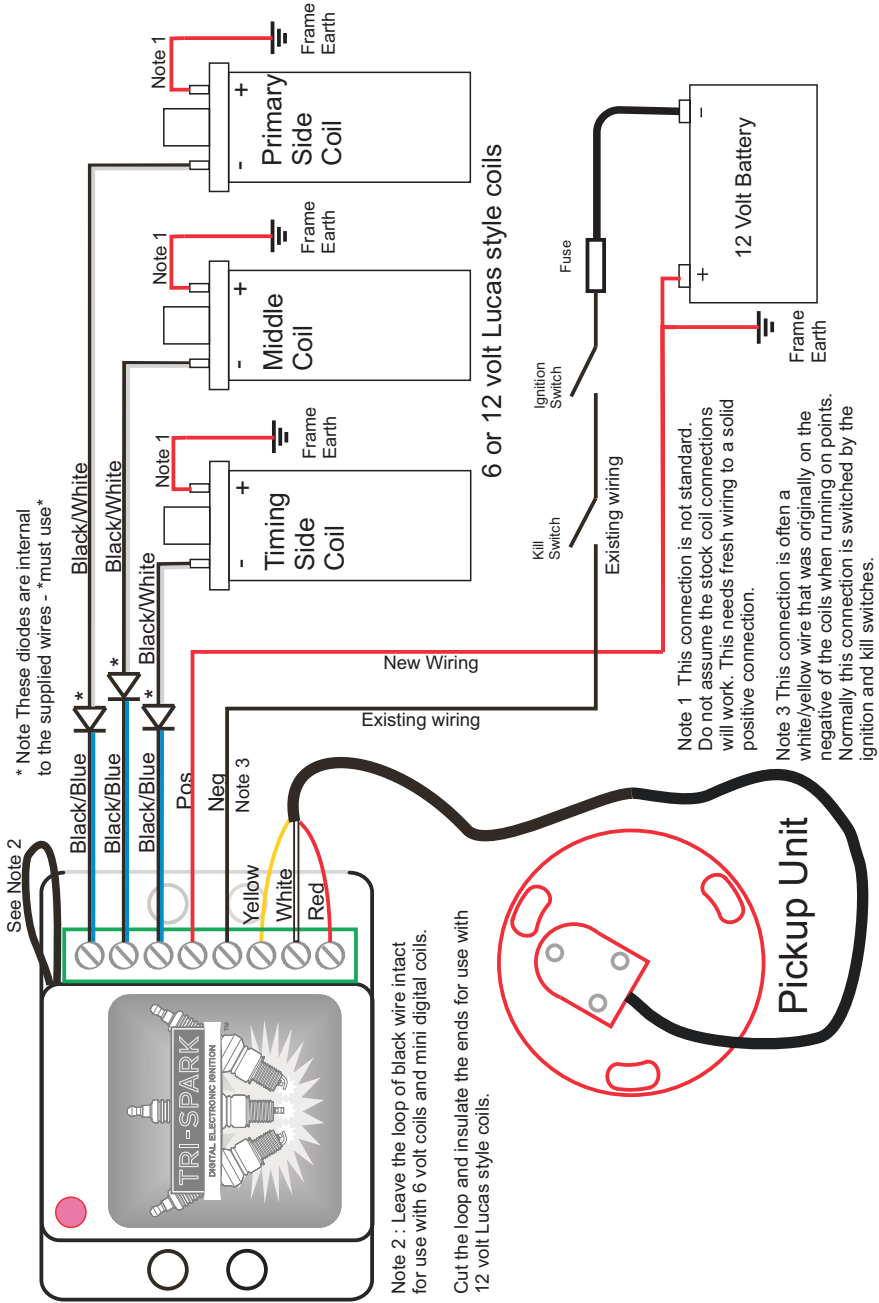

# Tri-Spark Triple Flex TRI-0003 Three coil installation - Negative Earth (Ground)

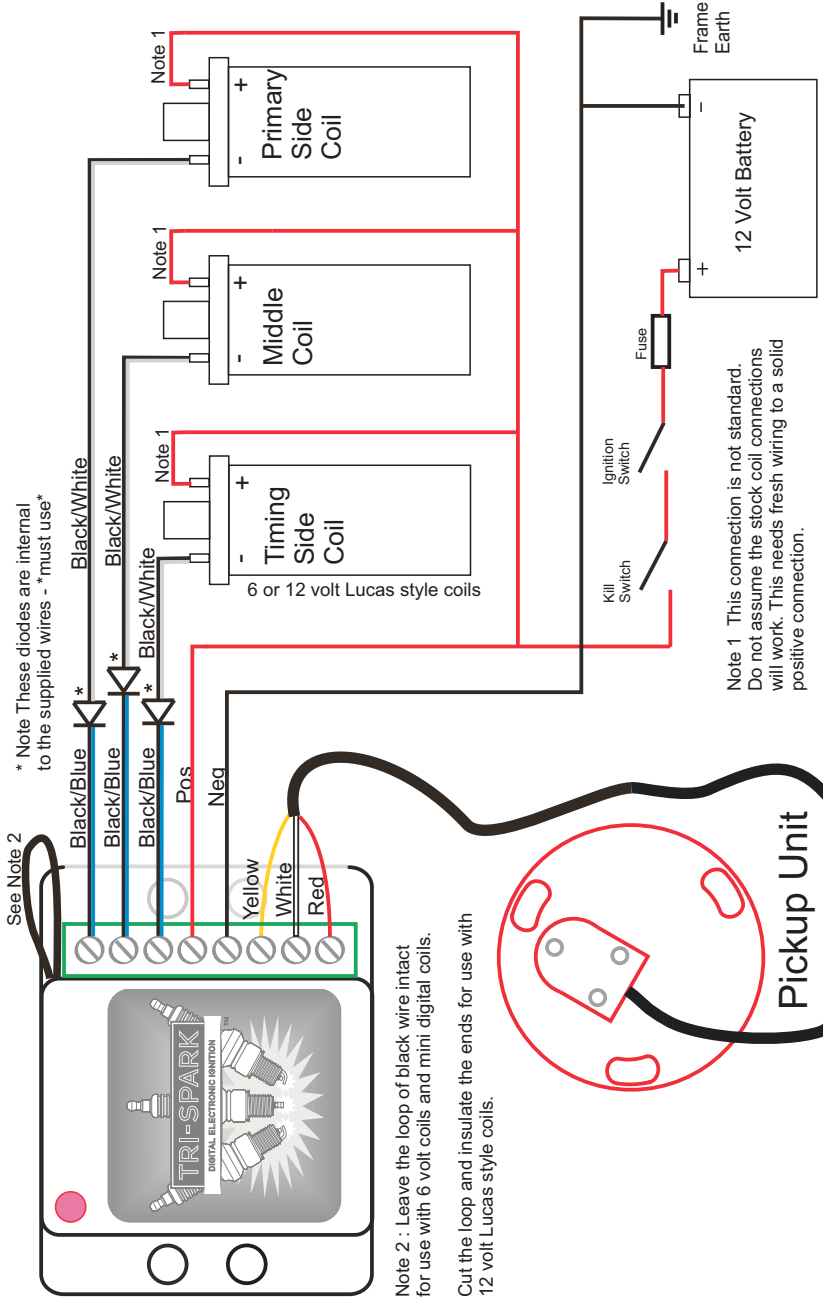

Note 2 : Leave the loop of black wire intact for use with 6 volt coils and mini digital coils.  
Cut the loop and insulate the ends for use with 12 volt Lucas style coils.

Note 1 This connection is not standard. Do not assume the stock coil connections will work. This needs fresh wiring to a solid positive connection.

# Tri-Spark Triple Flex TRI-0003 Mini digital coil installation - Positive Earth (Ground)

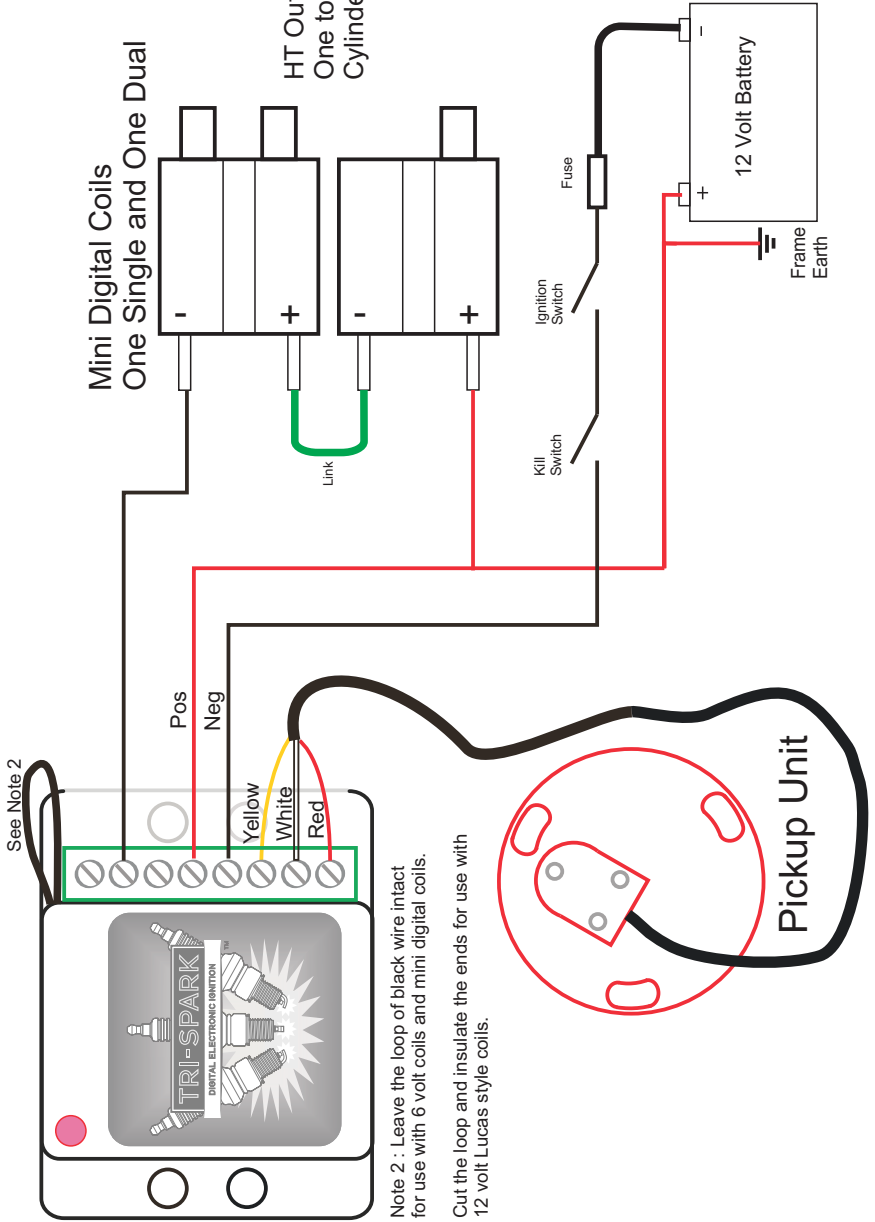

Note 2 : Leave the loop of black wire intact for use with 6 volt coils and mini digital coils.

Cut the loop and insulate the ends for use with 12 volt Lucas style coils.

# Tri-Spark Triple Flex TRI-0003 Mini digital coil installation - Negative Earth (Ground)

See Note 2

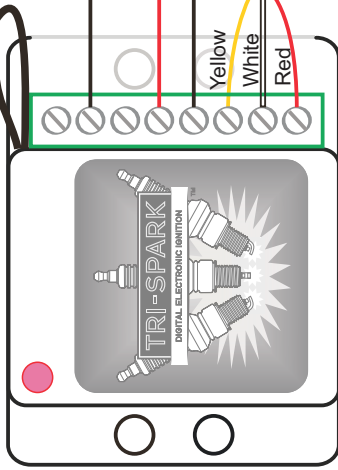

Note 2 : Leave the loop of black wire intact for use with 6 volt coils and mini digital coils.

Cut the loop and insulate the ends for use with 12 volt Lucas style coils.

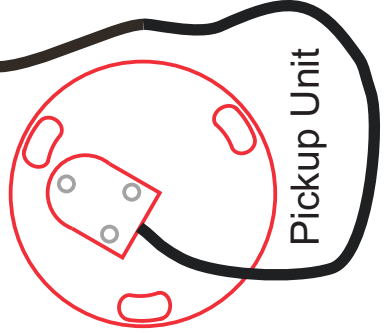
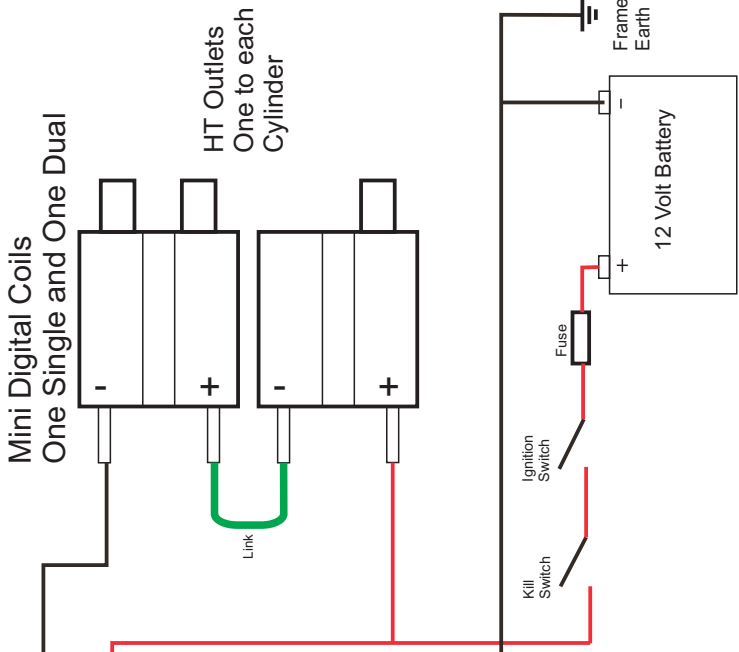



## Step 6 - Setting the timing statically using the LED

Double-check all the wiring carefully then reconnect the battery and main fuse.

The crankshaft must be positioned at 38 degrees BTDC for cylinder 1 (timing side) on the COMPRESSION stroke as per Step 3 instructions.

Loosen the bolts retaining the stator unit and rotate it clockwise as far as it will go. Switch on the ignition and monitor the LED on the control box. The LED should be off. Rotate the stator unit counter-clockwise to the position where the LED just turns on and tighten it up there. Now switch off the ignition.

If the LED is always on or does not switch on within the range of the adjustment slots, an adjustment to the position of the trigger rotor may be required.

## Step 7 - Checking the timing using a strobe timing light

Reassemble the motorcycle fully with all the parts (except the points cover) that were removed during the installation. Start and warm up the engine ready for checking with a timing light. Clip the timing light pickup onto the right hand cylinder (1) spark plug wire and aim the light into the strobe timing port.

As the revs are increased the timing mark should appear to smoothly shift and line up with the pointer at 4000 RPM and above.

Adjustment can be made to the position of the stator unit to fine tune the timing if it does not line up exactly at 4000 RPM. Always adjust for full advance timing not the idle.

If the correct adjustment cannot be achieved within the range of the adjustment slots, adjust the position of the trigger rotor by loosening the screw and repositioning the rotor.

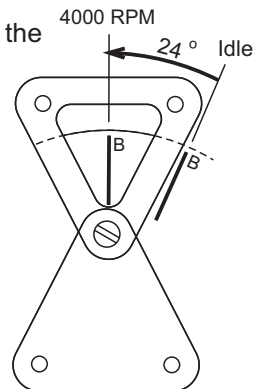

# Specifications

Nominal operating voltage: 12 volts (min 8V max 16V) positive or negative earth (ground)

Power consumption including coils: 3A Max (typically 2A)

Power consumption at idle: under 1 Amp

Power Consumption Stator unit only: < 25mA

Dwell time: 3 mS for 6 volt coils and mini coils - Black wire looped

Dwell time: 6 mS for 12 volt coils with the Black wire cut

Advance range: 24 degrees at crank (14 to 38 degrees BTDC)

Fully Advanced: at 3500 RPM

Idle stabilisation range: 500 to 1400 RPM

Advancing timing range: 1400 to 3500 RPM

Operating temperature range: -20 to 90 degrees Celsius

Absolute maximum input voltage: 24 volts DC for 1 minute

Maximum load dump voltage spike: 400 Volts DC for 20mS

Air Gap (rotor to stator unit): 2.0mm +/- 0.6mm

RPM range: 150 to 10000 RPM

Safety - Coils are always off when the engine is stopped

Ignition coil compatibility:

Tri-Spark IGC-1012 (12 volt) coils typ. 4.0 Ohm primary resistance

Tri-Spark IGC-1006 (6 volt) coils typ. 2.2 ohm primary resistance

Mini Digital coils may also be used when wired in series

4 volt coils are NOT recommended. Use of other than the recommended coils will damage the stator unit.

Specifications subject to change without notice.

- **General troubleshooting tips, installation notes, and cautions.**

- Take care! Do not probe around the wiring with the power on. Disconnect the fuse before attempting any adjustments or disassembly.
- Do not attempt to test for spark by 'hot wiring' or 'sparking' the coils as this can damage the Tri-Spark ignition.
- Do not run the bike without all spark plugs connected as this can damage the Tri-Spark system. If you wish to run the engine without all plugs firing, such as for tuning the carburetors, connect and earth a spare plug outside of the engine.
- It is recommended that resistor type spark plugs OR spark plug suppressor caps be used with this system. Use 5k Ohm plug caps such as NGK.

If the engine fails to start, you should check the following:

- Check the air gap between the trigger rotor and pickup unit is 2mm +/- 0.6
- Make sure the earth connections to the engine and frame are sound
- Check that fuel is getting through to carburetors
- Ensure that the battery is fully charged and in good condition
- Ensure that there is compression, there should be resistance felt on the kick start lever – pay particular attention to the valve clearances.

If there seems to be an ignition problem from first installation, reinstall the trigger rotor from the beginning of the installation procedure. Getting the rotor out of sync is a common installation error.

- The red LED on the control box should go on and off as you turn over the engine. The LED should come on as the piston rises on the compression stroke.

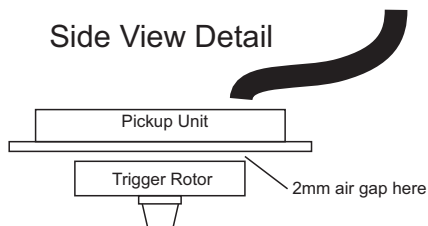

# Tri-Spark Classic Triple Warranty Policy

The Manufacturer Tri-Spark extends a Warranty to the original purchaser of this kit covering the stator unit and rotor components of the system (not sundry items) under normal use for a period of **three years from the date of purchase**. Only those parts which are deemed by Us to be defective due to faulty materials or workmanship in manufacturing shall be repaired or replaced under this Warranty. Conditions apply.

## Limitation of liability

It is the sole responsibility of the purchaser to determine the suitability of the product for a particular installation or purpose. Under no circumstances shall the Manufacturer Tri-Spark be liable for any consequential, special, incidental, direct or indirect damages arising from the use or lack of ability to use this product. The Manufacturer's liability under this Warranty is limited to the replacement of the product or its parts and no other obligations, expressed or implied are assumed by the manufacturer Tri-Spark. A refund option is not offered as part of this Warranty.

## Conditions

This Warranty will be void if the product or parts have been in any way misused, abused, altered or installed incorrectly as deemed by Us.

This Warranty will be void if faults are caused by but not limited to:

- 1) operation with incorrect coil circuit resistance
- 2) the rotor contacting the stator as evidenced by circular scratches
- 3) bending, cutting or any other physical damage to the parts
- 4) the ingress of oil, water or other liquid into the parts
- 5) exposure of the parts to solvents or chemicals
- 6) damaged or broken wires connecting to the parts
- 7) any modification to the parts not authorised by the Manufacturer
- 8) any electrical damage to the parts caused by voltage spiking from the battery, charging system, jump starting or any other devices connected to the electrical system.

The manufacturer reserves the right to charge a testing fee of \$50AUD and a return freight fee of \$30AUD in cases where parts returned to Us are found to be functional.

The purchaser is responsible for the cost of freight, customs duties, taxes and tariffs to and from the point of purchase where the part or parts shall be assessed for possible replacement. Recorded delivery is recommended to protect against loss.

**To make a claim under this Warranty** the purchaser is requested to contact the point of purchase for instructions. The purchaser may be asked to perform certain tests to determine the nature of the problem. The suspected faulty part(s) must be returned with proof of purchase and a detailed account of the problem to the point of purchase or the Manufacturer for testing and possible replacement. Returned parts must be sent with freight prepaid.

## Statutory rights

Your statutory rights are unaffected. Additionally, if any statement herein is deemed to be invalid then only that statement shall be deemed invalid. The Laws of South Australia shall apply to purchases made directly from the Manufacturer.