

Tri-Spark - Classic Triple Trident & R3 Installation Instructions

TRI-0002 Mark II

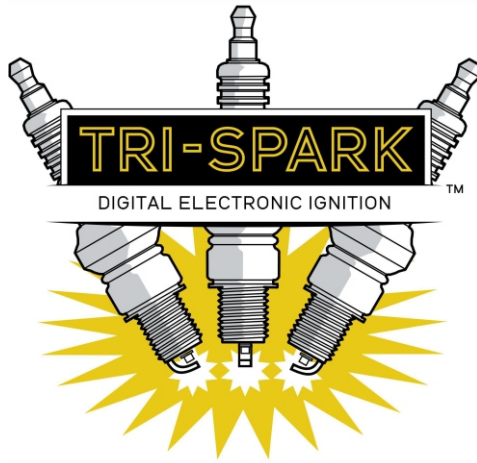

Introduction

Thank you for purchasing the Tri-Spark Classic Triple Ignition system. For your own safety and success with the installation we strongly recommend that you engage a qualified technician to install your new ignition system. The following information is provided to assist them in the installation and setup.

Manual Contents	Page
Preparation	2
Remove the points plate and advancer	3
Install trigger rotor and stator unit	4
Wiring Diagram Positive Earth	5
Wiring Diagram Negative Earth	6
Static Timing	7
Strobe Timing	7
Side View Air Gap	8
Self Test Mode	8
Specifications	9
Troubleshooting	10
Warranty policy	12

Step 1: Preparation

Read all the instructions before you begin. Disconnect the battery, remove fuse, seat, side covers and points cover in preparation.

Caution: A general inspection and tidy up of all wiring including inside the headlight shell is highly recommended. Inspection and testing of the charging system prior to installing the system is also **highly recommended**.

Caution: Use the recommended 12 volt Lucas style canister ignition coils (Tri-Spark part IGC-1012). Other coils may damage the ignition unit.

Use resistor spark plug caps OR resistor type spark plugs.

Step 2 - Remove the original points base plate and auto advance unit

Remove the points base plate and auto advance unit (AAU). If you have other electronic ignition parts (pickup and trigger rotor) remove those instead.

Disconnect the points plate wiring from the connectors located along the frame. This is made easier if the air filter and side cover are first removed to gain access to the area.

With the pillar bolts removed, the points plate hangs from the wiring. Pull the wires through and remove the whole unit from the engine including the wires.

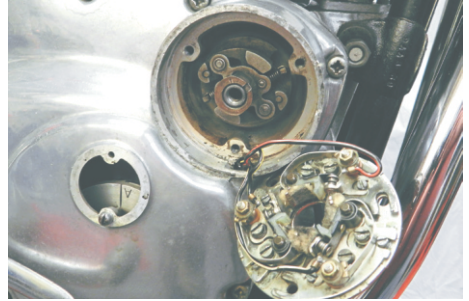

Remove the fixing bolt in the centre of the AAU. A threaded rod or bolt then goes into the AAU to assist removal. The AAU fits into a taper in the exhaust cam and may be difficult to remove.

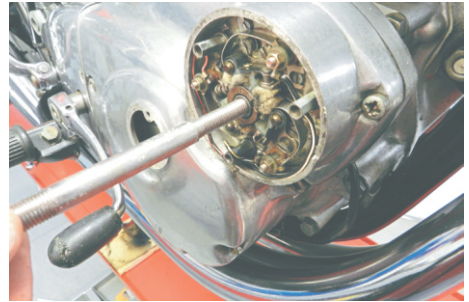

A few gentle taps with a hammer should get things moving. The AAU comes out as a complete unit.

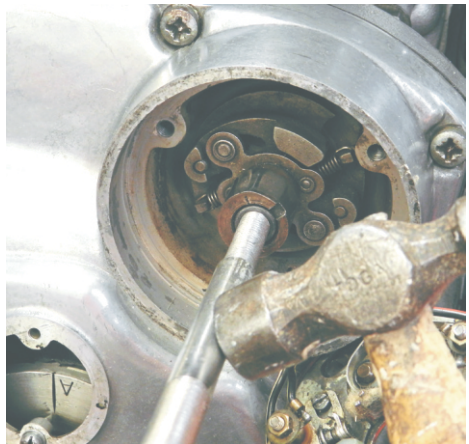

Step 3 - Install the Tri-Spark Trigger Rotor

Select high gear so that the rear wheel can be used to rotate the crankshaft. Rotate the crankshaft forward to top dead centre (TDC) on the number 1 Timing Side cylinder on COMPRESSION STROKE. Both valves should be closed on the compression stroke. The Timing side is your right side as you sit on the bike.

With the timing plunger (Triumph tool #60-1858) screwed into the access hole in the front of the engine, apply light finger pressure on the plunger while slowly rotating the engine BACKWARDS until the plunger engages into the crankshaft. The "A" or the "B" timing line should now line up with the pointer in the strobe timing port as shown here.



If the plunger tool is not available simply rotate the crank backwards from TDC until the FIRST timing mark lines up with the pointer as shown. In most cases this will be the "B" mark. The crank should now be lined up at 38 degrees BTDC ready for the installation.



Install the trigger rotor as shown above 22mm centre to centre from the magnet to the bolt hole. The socket head screw provided is the correct 1/4 UNF thread - it should go in easily. If it bottoms you will need to shorten it - don't force it !

Important! Check that the face of the rotor is 2mm (+/- 0.6) below the deck that the stator unit sits on. Use the plastic strip provided as a guide. See diagram on page 8.

Step 4 - Install the Tri-Spark Stator Unit

Install the stator unit as shown here so that the bolts are in the middle of the adjustment slots. Feed the cable through the wire hole carefully. Adjust the cable so that the amount of slack inside the engine looks exactly like the photo.

Run the cable along the bottom frame rail and up the frame beside the oil tank. Pay attention to keep the cable well away from the exhaust pipes and moving parts.



Step 5 - Connect the wiring

Refer to the wiring diagrams on the following pages. Connect the wiring as shown in the diagram that suits your machine (positive or negative earth). The cable may be cut to length but leave some slack.

Tri-Spark Classic Triple TRI-0002 Mark 2 Installation - Positive Earth

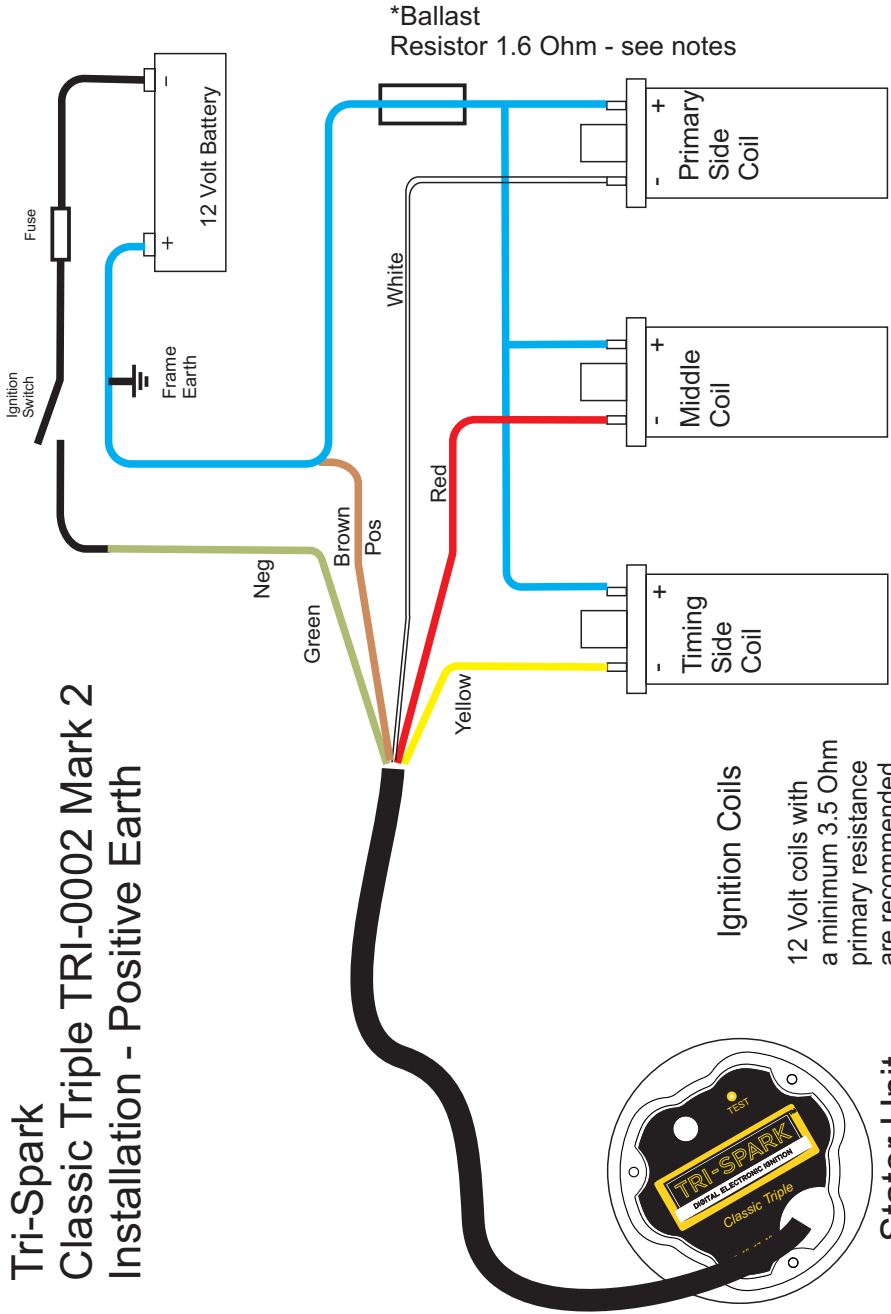

*Ballast Resistor 1.6 Ohm - see notes

Ignition Coils

12 Volt coils with a minimum 3.5 Ohm primary resistance are recommended.

A Ballast resistor MUST be installed here* if 6 volt coils are to be used
Warning - the system WILL BE DAMAGED if used with other coils

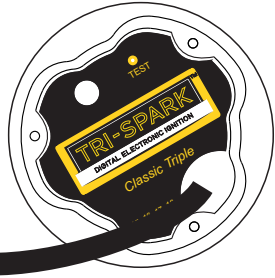

Stator Unit

Tri-Spark Classic Triple TRI-0002 Mark 2 Installation - Negative Earth

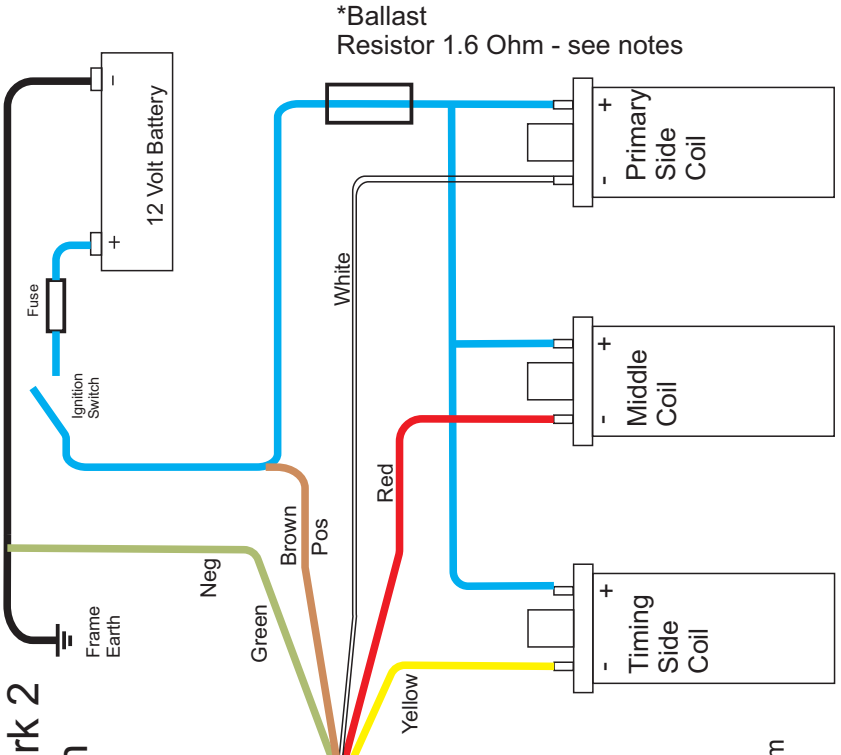

*Ballast
Resistor 1.6 Ohm - see notes

Ignition Coils

12 Volt coils with a minimum 3.5 Ohm primary resistance are recommended.

A Ballast resistor **MUST** be installed here* if 6 volt coils are to be used
Warning - the system **WILL BE DAMAGED** if used with other coils



Stator Unit

Step 6 - Setting the timing statically using the LED

Check that the wiring from Step 5 is correct, then reconnect the battery and main fuse.

The crank must be at 38 degrees BTDC for cylinder 1 (timing side) on COMPRESSION stroke as per Step 3 instructions.

Loosen the bolts retaining the stator unit and rotate clockwise as far as it will go. Switch on the ignition and monitor the LED on the stator unit which should be off. Rotate the stator unit counter-clockwise to the position where the LED just turns on and tighten it up there. Now switch off the ignition.

If the LED is always on or does not switch on within the range of the adjustment slots, an adjustment to the position of the trigger rotor may be required.

Step 7 - Checking the timing using a strobe timing light

Reassemble the motorcycle fully with all the parts (except the points cover) that were removed during the installation. Start and warm up the engine ready for timing with a strobe timing light. Clip the pickup from the strobe light onto the right hand cylinder (1) spark plug wire and aim the light into the strobe timing port.

As the revs are increased the timing mark should appear to smoothly shift and line up with the pointer at 4000 RPM and above.

Adjustment can be made to the position of the stator unit to fine tune the timing if it does not line up exactly at 4000 RPM. Always adjust for full advance timing not the idle.

If the correct adjustment cannot be achieved within the range of the adjustment slots, adjust the position of the rotor slightly by loosening the screw and repositioning the trigger rotor.

Also check the timing for cylinders 2 and 3.

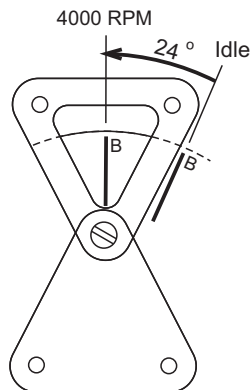

Side View Detail

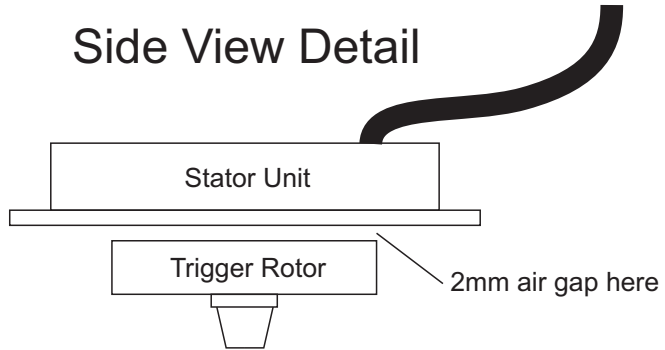

Self Test Mode

These notes explain how to use the TEST feature on the TRI-0002. By switching on the test mode it is possible to check the operation of the stator unit, rotor, coils, HT leads and spark plugs without starting the engine.

Warning: the system is capable of sparking the coils in this mode - extreme care must be taken to ensure there is no risk of fire or electric shock that can arise from switching on the test mode. Make sure there is no fuel in the vicinity of the spark plugs. Keep children and pets well away. We strongly advise engaging a technician to perform these tests in the safety of a fully equipped motorcycle workshop.

Test 1: Start by removing the spark plugs from the engine and earthing them on the cylinder head. The test switch is located above the word 'TEST' on the stator unit.

Press and HOLD DOWN the test switch very gently with the tip of a pen WHILE switching on the power to the ignition (ignition key switch). The test switch must be **held down while** the power is switched on to start the testing. The spark plugs should begin sparking immediately at a rising rate for 6 seconds and then stop.

Test 2: WITHOUT SWITCHING OFF THE POWER a second test **MUST** be performed to check the 3 triggers in the stator unit. Rotate the engine slowly until the red LED on the stator unit lights. The LED should light when the magnet rotor triggers one of the position sensors. The corresponding spark plug should also spark slowly. Rotate the engine to check each trigger. **ALL THREE POSITIONS SHOULD TRIGGER ONE OF THE SPARK PLUGS.**

The system is functioning normally if **BOTH** tests are passed.

Important Note: The ignition switch must be switched off to power down the stator unit in order to exit the test mode before attempting to start the engine.

Specifications

Nominal operating voltage: 12 volts (min 8V max 16V) positive or negative earth (ground)

Power consumption including coils: 3A Max (typically 2A)

Power consumption at idle: under 1 Amp

Power Consumption Stator unit only: 25mA

Coil circuit resistance range: 3.0 to 5.0 Ohms (3.0 absolute minimum)

Dwell time: 8 mS nominal

Advance range: 24 degrees at crank (14 to 38 degrees BTDC)

Fully Advanced: at 3500 RPM

Idle stabilisation range: 500 to 1200 RPM

Advancing timing range: 1200 to 3500 RPM

Operating temperature range: -20 to 110 degrees Celsius

Absolute maximum: 24 volts DC for 1 minute

Maximum load dump voltage spike: 180 Volts DC for 50mS

Air Gap (rotor to stator unit): 2.0mm +/- 0.6mm

RPM range: 150 to 10000 RPM

Safety - Coils are always off when engine stopped

Ignition coil compatibility:

Tri-Spark IGC-1012 (12 volt) coils are recommended 3.5 Ohm Primary resistance

Note: 6 volt coils (typ. 1.8 ohm primary) may be used with a ballast resistor(1.6 Ohm). 4 volt coils are not recommended. Use of other than the recommended coils will damage the stator unit.

Specifications subject to change without notice.

- **General troubleshooting tips, installation notes, and cautions.**
- Take care! Do not probe around the wiring with the power on. Disconnect the fuse before attempting any adjustments or disassembly.
- Do not attempt to test for spark by 'hot wiring' or 'sparking' the coils as this can damage the Tri-Spark ignition.
- Do not run the bike without all spark plugs connected as this can damage the Tri-Spark system. If you wish to run the engine without all plugs firing, such as for tuning the carburettors, connect and earth a spare plug outside of the engine.
- It is recommended that resistor type spark plugs OR spark plug suppressor caps be used with this system. Use 5k Ohm plug caps such as NGK.

If the engine fails to start, you should check the following:

- Spark plug leads (high tension leads) connected and tight
- Earth connections to the engine and frame are sound
- Check that fuel is getting through to carburettors
- Ensure that the battery is fully charged and in good condition
- Ensure that there is compression, there should be resistance felt on the kick start lever – pay particular attention to the valve clearances.

If there seems to be an ignition problem from first installation, reinstall the trigger rotor from the beginning of the installation procedure. Getting the rotor out of sync is a common installation error.

- The red LED on the stator unit should go on and off as you turn over the engine. The LED should come on as the piston rises on the compression stroke.
- Check that the clearance between the rotor and stator unit is 2.0 mm.
- The LED should switch on as the rotor magnet passes each sensor.
- Perform the Self Test as detailed on the page 8.

Troubleshooting Continued.....

- To find a misfire issue, the spark plugs can be tested individually
- It is possible to check for spark from the plugs by having the plugs resting on the head, or similarly earthed position.
- Kick over the engine, the plugs should spark, along with the LED pulsing.
- If the LED lights as it should but the plug does not spark, first ensure the plug body is earthed correctly. If there is still no spark, try installing a new plug, then try swapping the high tension leads.
- If the either of these swaps corrects the problem, replace the offending part.
- If only one or 2 spark plugs are firing there may be a fault with an ignition coil.

Troubleshooting FAQ

Q: My engine's running badly - what should I do?

A: Try a new set of spark plugs (really new - out of the box) before anything else. If the problem clears even temporarily it was probably due to fouled plugs. This is the most common problem. Cleaning the spark plug may not fix the problem.

Q: The engine runs but doesn't idle smoothly - is this the ignition?

A: A variable idle and stalling out are often indications of worn out carburettors.

Q: What causes some of the most commonly reported faults?

A: Wiring faults are common with old bikes. Battery trouble too. Common places to look for a fault are, the main fuse (melted, bent or dirty contacts), inside the headlight shell (particularly the nylon connector blocks), ignition switch, kill switch, wire chaffing (look under the fuel tank, inside the rear mudguard, behind side covers), wires melted on the exhaust system, ignition coil connections and earth connections (frame and engine).

Q: How do I test for signals within the stator?

A: Apart from the power connections, all other signals are electronic pulses and should not be tested for with simple lamp testers and meters.

Please note: the information in this document relates to the Tri-Spark system (p/n TRI-0002) only and should not be applied to any other product.

Tri-Spark Classic Triple Warranty Policy

The Manufacturer Tri-Spark extends a Warranty to the original purchaser of this kit covering the stator unit and rotor components of the system (not sundry items) under normal use for a period of **five years from the date of purchase**. Only those parts which are deemed by Us to be defective due to faulty materials or workmanship in manufacturing shall be repaired or replaced under this Warranty. Conditions apply.

Limitation of liability

It is the sole responsibility of the purchaser to determine the suitability of the product for a particular installation or purpose. Under no circumstances shall the Manufacturer Tri-Spark be liable for any consequential, special, incidental, direct or indirect damages arising from the use or lack of ability to use this product. The Manufacturer's liability under this Warranty is limited to the replacement of the product or its parts and no other obligations, expressed or implied are assumed by the manufacturer Tri-Spark. A refund option is not offered as part of this Warranty.

Conditions

This Warranty will be void if the product or parts have been in any way misused, abused, altered or installed incorrectly as deemed by Us.

This Warranty will be void if faults are caused by but not limited to:

- 1) operation with incorrect coil circuit resistance (under 3 ohms)
- 2) the rotor contacting the stator as evidenced by circular scratches
- 3) bending, cutting or any other physical damage to the parts
- 4) the ingress of oil, water or other liquid into the parts
- 5) exposure of the parts to solvents or chemicals
- 6) damaged or broken wires connecting to the parts
- 7) any modification to the parts not authorised by the Manufacturer
- 8) any electrical damage to the parts caused by voltage spiking from the battery, charging system, jump starting or any other devices connected to the electrical system.

The manufacturer reserves the right to charge a testing fee of \$45AUD and a return freight fee of \$30AUD in cases where parts returned to Us are found to be functional.

The purchaser is responsible for the cost of freight, customs duties, taxes and tariffs to and from the point of purchase where the part or parts shall be assessed for possible replacement. Recorded delivery is recommended to protect against loss.

To make a claim under this Warranty the purchaser is requested to contact the point of purchase for instructions. The purchaser may be asked to perform certain tests to determine the nature of the problem. The suspected faulty part(s) must be returned with proof of purchase and a detailed account of the problem to the point of purchase or the Manufacturer for testing and possible replacement. Returned parts must be sent with freight prepaid.

Statutory rights

Your statutory rights are unaffected. Additionally, if any statement herein is deemed to be invalid then only that statement shall be deemed invalid. The Laws of South Australia shall apply to purchases made directly from the Manufacturer.